

CONCRETE BLOCK PAVING

Book 2 – Design Aspects

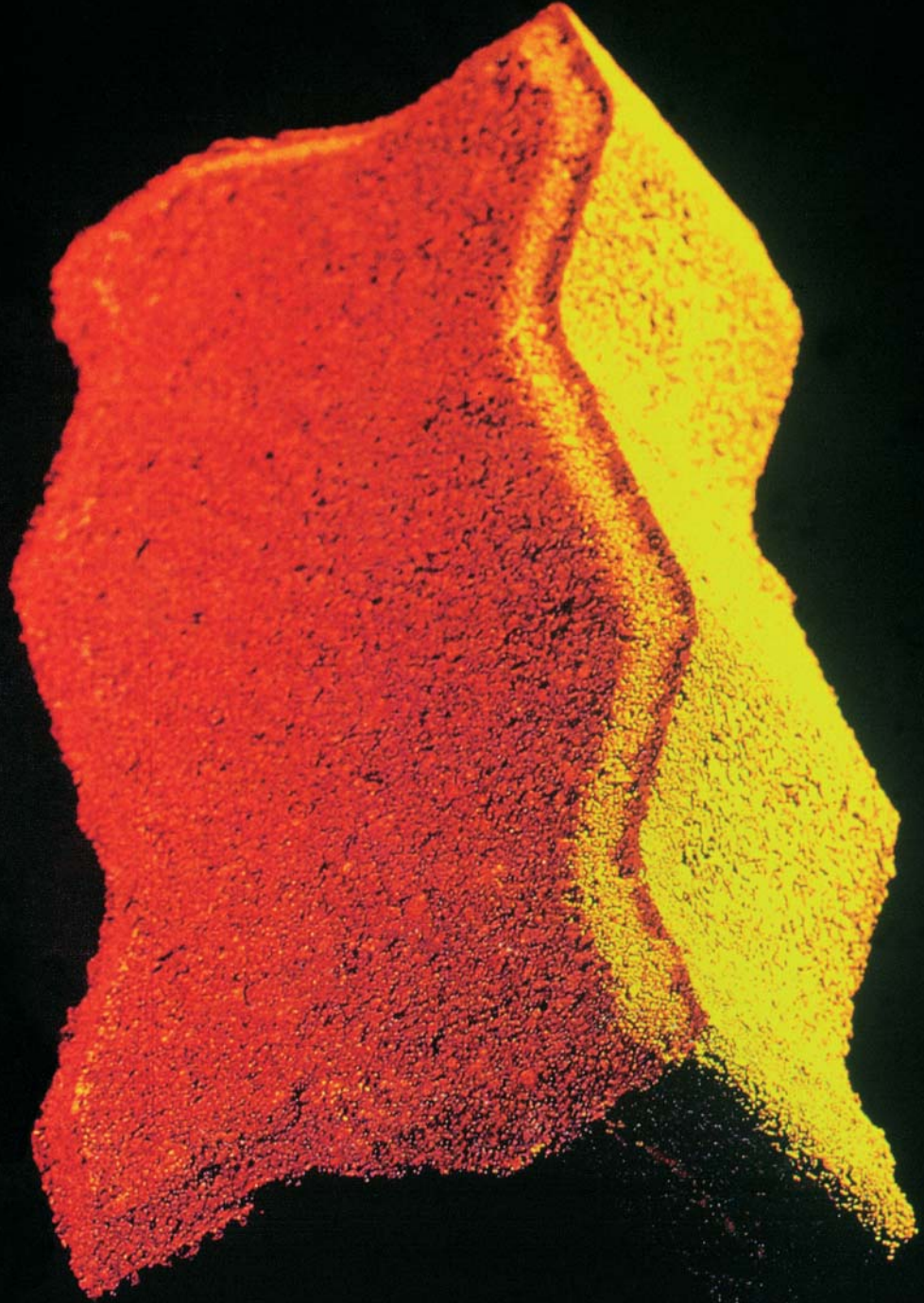

***A walk-over in cost, looks and
durability for Concrete Block Paving***

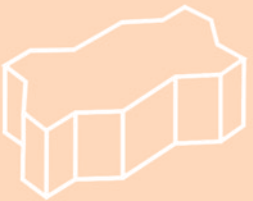
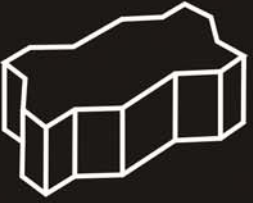



Concrete Block Paving
Book 2: Design Aspects
Published by the Concrete Manufacturers Association
Portland Park, Old Pretoria Road, Halfway House 1685
P.O. Box 168, Halfway House, 1685
Telephone +27 11 805 6742
Fax +27 11 315 4683
e-mail cma@cis.co.za
Web Site: <http://www.cma.org.za>
Fourth edition 2004

PAVING MEMBERS (SEPTEMBER 2004)

PRODUCER MEMBERS

*Companies which hold the SABS mark

Altocrete	(016) 363-0340.
Bamburi Special Products – Kenya	(09254) (2)824-478
Baybrick	(035) 791-1256
Bosun Brick*	(011) 310-1161
Brickbuild – Botswana	(09267) 241-4089
Brick & Concrete Industries – Namibia	(09264) (61) 280-4103
Brickcast Industries*	(031) 507-7094
Cape Brick	(012) 511-2006
Cast Industries*	(011) 316-2375
C.E.L. Paving Products	(021) 905-5998
Columbia – DBL*	(021) 905-1665
Concor Technicrete*	(011) 495-2200
Consteen	(011) 701-3875
Corobrik*	(031) 560-3911
Deranco Blocks*	(041) 463-3338
Ecco-Euro Paving	(011) 786-3109
False Bay Bricks	(021) 904-1620
Infrasret*	(012) 652-0000
	(031) 705-2323
Inca Masonry Products*	(043) 745-1215
Kwena Brickforce – Botswana	(09267) 322-850
Mimosa	(016) 362-0507
MVA Bricks*	(012) 386-0050
Neat Contech*	(046) 648-1359
Stanger Brick & Tile*	(032) 457-0237
Vanstone*	(012) 541-2056
Vibro Bricks*	(012) 374-2032
White River Cement Bricks	(013) 750-1271

NON-PRODUCER MEMBERS

Brick King & Associates	(021) 948-6218
Inca (Cape)	(021) 904-1620

CONTRACTOR MEMBERS

Daron Construction	(034) 955-1333
Kay Crete	(031) 765-2830
Oryan Projects	(083) 327-6877
Pave Show	(012) 346-6958
PYW Paving	(031) 903-2104
Roadstone Civil & Paving	(083) 266-3183
SA Paving, Gauteng	(011) 483-1350
Sun Paving	(031) 705-5123
The Paving Syndicate	(011) 640-3333
Valcal International	(011) 867-2771
Vesles Civils	(012) 662-3030



Portland Park, Old Pretoria Road, Halfway House 1685, South Africa.
PO Box 168 Halfway House 1685

Tel +27 11 805 6742, Fax +27 11 315 4683
e-mail: cma@cis.co.za website: www.cma.org.za

CONCRETE BLOCK PAVING
Book 1 – Introduction

A walk-over in cost, looks and durability for Concrete Block Paving

CONCRETE BLOCK PAVING
Book 2 – Design Aspects

A walk-over in cost, looks and durability for Concrete Block Paving

CONCRETE BLOCK PAVING
Book 3 – Specification & Installation

A walk-over in cost, looks and durability for Concrete Block Paving

CONCRETE BLOCK PAVING
Book 4 – Site management and laying

A walk-over in cost, looks and durability for Concrete Block Paving

CONCRETE BLOCK PAVING
Book 5 – Training Manual

A walk-over in cost, looks and durability for Concrete Block Paving

CONCRETE BLOCK PAVING
Book 6 – Facilitators Guide

A walk-over in cost, looks and durability for Concrete Block Paving



Portland Park, Old Pretoria Road, Halfway House 1685, South Africa.
PO Box 168 Halfway House 1685
Tel +27 11 805 6742, Fax +27 11 315 4683
e-mail: cma@cis.co.za website: www.cma.org.za

CONTENTS

1. INTRODUCTION	2
2. KEY ELEMENTS OF PAVING	2
2.1 Subgrade	2
2.2 Subbase	2
2.3 Bedding sand layer	3
2.4 Concrete paving blocks	3
2.5 Jointing sand	4
2.6 Edge restraints	4
2.7 Drainage	4
3. STRUCTURAL DESIGN OF CBP	4
3.1 Equivalent thickness concept	6
3.2 Catalogue design method	6
3.3 Research-based method	6
3.4 Mechanistic design method	6
3.5 Lockpave	8
4. PRELIMINARY DESIGN CONSIDERATIONS	9
4.1 Preliminary considerations	9
4.2 Construction	9
5. SPECIAL APPLICATIONS	9
5.1 Construction of steep slopes	10
5.2 Embankments	10
5.3 Intersections	10
5.4 Airports	10
5.5 Roof decks	10
6. MAINTENANCE	10
6.1 Jointing sand	10
6.2 Weed growth	11
6.3 Abrasion	11
6.4 Settlement/subsidence	11
6.5 Reinstatement of trenches	11
6.6 Efflorescence	11
6.7 Oil Stains	11
7. CONCLUSION	11
8. CASE STUDIES	12
8.1 Richards Bay Harbour	12
8.2 Pinetown Traffic Intersection	12
8.3 Bellville Goods Yard	13
8.4 Trident Steel Maxmead Pinetown	14
8.5 Johannesburg Northern Wastewater Treatment Works	14
8.5 Pietersburg Traffic Intersection	15
8.6 Analysis of a Concrete Segmental Road Pavement	16
9. REFERENCES	16



INTRODUCTION

Concrete block paving (cbp), if properly designed and constructed, will last for decades with little or no maintenance being necessary. However, as with all types of pavements and structures, there are certain requirements regarding the design and construction, which are important to the success of cbp. This publication covers some of these aspects, which are critical to the successful long-term performance of segmented paving. History of the design philosophy is also covered.

The structural design of pavements is concerned with traffic, layerwork (foundations), materials, subgrade soils, environmental conditions, construction details and economics. Essentially the pavement must carry the traffic at an acceptable level of comfort and safety and at an acceptable cost. This is achieved by a layered structure where each layer has sufficient strength to cope with the induced stresses without distress such as rutting, excessive settlement or deflection. Figure 2 shows how the pressure exerted by traffic dissipates under the road.

Although the surfacing is subjected to the highest stresses, the effect of traffic (especially heavy traffic) is felt deep into the pavement layers, sometimes up to a metre deep. The strength of these layers is as important to the long-term performance of the pavement as the surface itself.

Concrete paving blocks not only provide a durable wearing surface, but also provide a structural component and hence contribute to the strength of the pavement. They reduce the stresses in the layers below. Not all pavement requirements are equal, and every pavement should be designed and constructed to suit the particular need.

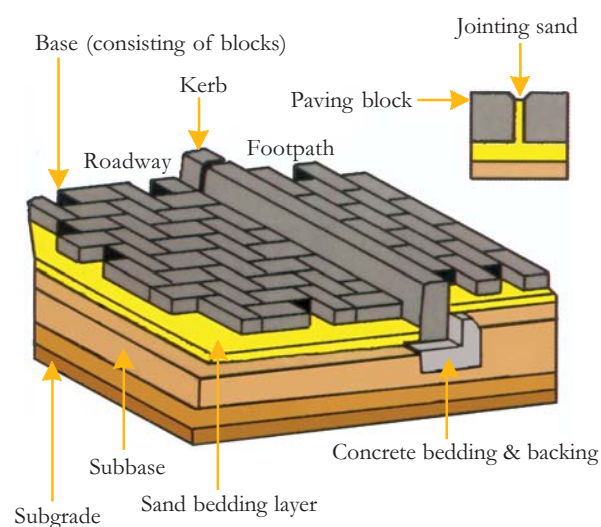

Figure 1: Key elements of paving.

2 KEY ELEMENTS OF PAVING

The seven key elements of paving are:

- The subgrade or natural earth material found on site
- The subbase, a layer of road building material imported when subgrade conditions are poor and/or traffic conditions are heavy.
- A thin layer of selectively graded bedding sand
- The concrete paving blocks, which form the base course as well as the surface wearing course
- The jointing sand that fills the gaps between every adjacent block
- Edge restraints, positive support placed around the perimeter of the pavement
- Drainage, both surface and subsoil, preventing the build-up of water in the pavement layers.

2.1 SUBGRADE

All structures-buildings, roads and other surfaced areas-are ultimately supported by soil or rock. It is the designer's responsibility to evaluate the behaviour and performance requirements of the structure to ensure such requirements are compatible with the soil conditions prevailing on the site. Subgrade preparation should extend to the rear face of all new edge restraints.

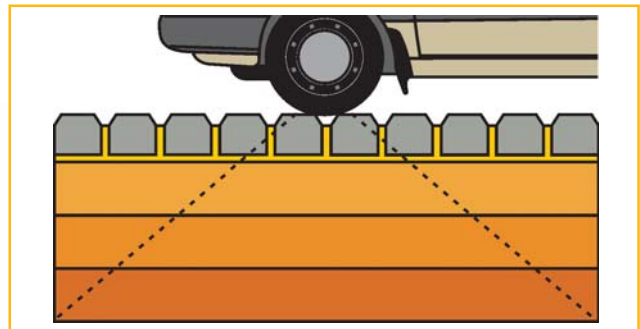

Figure 2: Dissipation of traffic loading.

2.2 SUBBASE

Where the subgrade is of a low strength, or the traffic is heavy, an imported subbase layer (or two or more layers) may be required or treatment of the subgrade eg stabilised. The principles of design of the pavement layers are the same as for most flexible pavements. As the blocks perform a structural function, the requirements for the layerworks are less than for asphalt. In many cases the subbase course can be eliminated.

Where the subbase is an unbound granular layer, it may in some cases be advisable to seal the surface if it is felt that, during the early life of the pavement, a

danger of water filtering through the joints and into the subgrade exists. Sealing can be achieved by spraying a low-durability bitumen emulsion at a rate of approximately 0,2ℓ/m². This is generally only a temporary problem, since the joints between the units eventually become clogged with road detritus and impermeable to water.

2.3 BEDDING SAND LAYER

This is a thin (25mm ± 10mm after compaction) layer usually of coarse river sand. The purpose of this layer is to provide an even bedding for the blocks. The bedding sand is laid loose and the blocks compacted into this layer with sand rising in the joints between blocks. This ensures that the blocks achieve an even support.

Generally, commercial clean river sand is satisfactory. Crusher sand may be suitable but needs to be evaluated for suitability.

The bedding sand pushed up into the joints between the blocks ensures adequate joint width and results in interlock when the joints are completely filled with jointing sand. The bedding sand layer should be thin, clean, free of silt and should not be used as a levelling course to fill voids in the subbase surface. This will lead to subsequent settlement.

2.4 CONCRETE PAVING BLOCKS

There are a number of aspects of paving blocks which should be considered during the design stage, namely the strength, shape, thickness and dimensional tolerance.

STRENGTH

Segmented paving blocks generally have an average compressive strength of 25MPa wet strength (Class 25 SANS1058) ¹. This is significantly higher than the strength of bricks (7 MPa). The reason for this is to ensure that the blocks have adequate resistance to traffic loading and to abrasion from traffic, both vehicular and pedestrian. Research carried out by CSIR Road Research ² shows that for strengths in excess of 25 MPa, little structural advantage is gained by increasing strength. It is also important to note that although the required average strength is 25 MPa, the minimum strength for individual blocks is 20 MPa. Very often it will be this lower figure that will dictate the average strength for compliance with Class 25 blocks. Where the quality control is poor it is virtually impossible to satisfy this latter requirement.

BLOCK SHAPE

Concrete paving blocks can be divided into three types based on shape (see Figures 3a, 3b and 3c).

Research shows that type S-A blocks develop the best resistance to both vertical and horizontal creep and are generally recommended for all industrial and heavy-duty applications. Type S-B and S-C blocks are generally selected for aesthetic reasons.

THICKNESS

Paving block thicknesses vary between 50 – 80 mm. The thicker the blocks the better the pavement will resist vertical deformation and horizontal creep. However, there is a cost implication and thickness selection should be based on application. Generally for domestic use, 50 – 60 mm blocks are adequate. For industrial use an 80mm



Block type S-A

Figure 3a: Type S-A: Those blocks which allow geometrical interlock between all vertical or side faces of adjacent blocks.

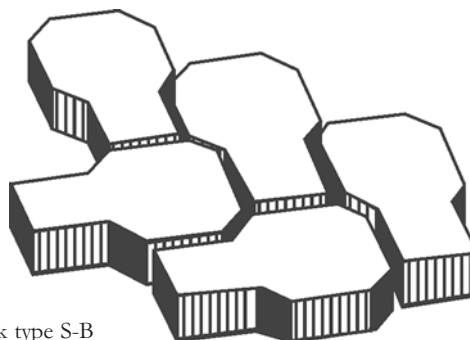

Block type S-B

Figure 3b: Type S-B: Those blocks which allow geometrical interlock between some faces of adjacent blocks.

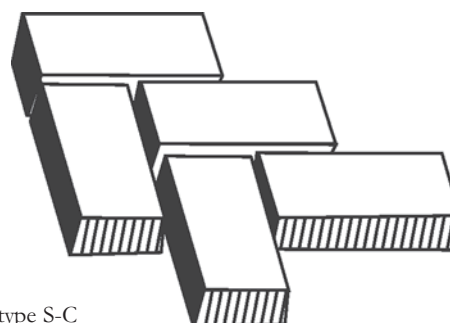

Block type S-C

Figure 3c: Type S-C: Those blocks which allow no geometrical interlock between adjacent blocks.



paver is recommended. Experience has shown that very little benefit is gained from pavers which are thicker than 80 mm. However, such pavers can be manufactured for special applications.

DIMENSIONAL TOLERANCE

It is important for blocks to be within the required dimensional specifications ($\pm 2\text{mm}$ on plan dimensions and $\pm 3\text{mm}$ on height). This is to ensure a smooth finished surface as well as good interlock between pavers.

CHAMFER

Chamfering of blocks improves their service performance and appearance. Most concrete paving blocks are chamfered.

LAYING PATTERNS

Patterns are determined by performance and aesthetic requirements. The three patterns shown (see Figures 4a, 4b and 4c) are the basic patterns. Numerous other patterns are also possible.

The herringbone pattern ensures the best resistance to both horizontal and vertical deformation and is generally recommended for industrial pavements.

The introduction of coloured blocks will add another dimension to the visual effect created by concrete block paving (see Book 1).

2.5 JOINTING SAND

The jointing sand plays an important role in the performance of concrete block pavements. This sand is distinctly different from the bedding sand (see Figure 5) and the same sand should not be used in both

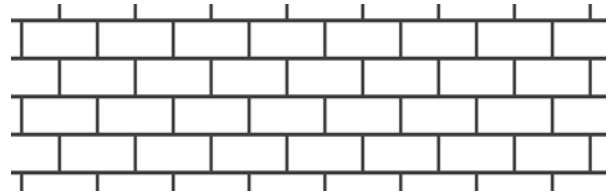

Figure 4a: Stretcher

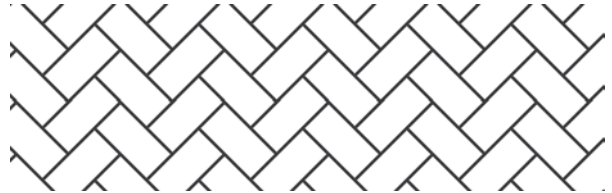

Figure 4b: Herringbone

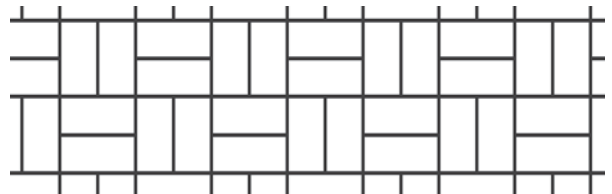

Figure 4c: Basket Weave

cases. Coarse river sand is ideal for bedding, while a finer plaster sand is necessary for jointing between the paving blocks.

Jointing sand is swept into the joints once the initial compaction of the blocks is complete. The jointing sand should ideally contain a little clay or silt. This helps seal the joints against water ingress.

Cement should not be added to the jointing sand as this will lead to cracking and subsequent water ingress. Cemented joints convert a flexible pavement

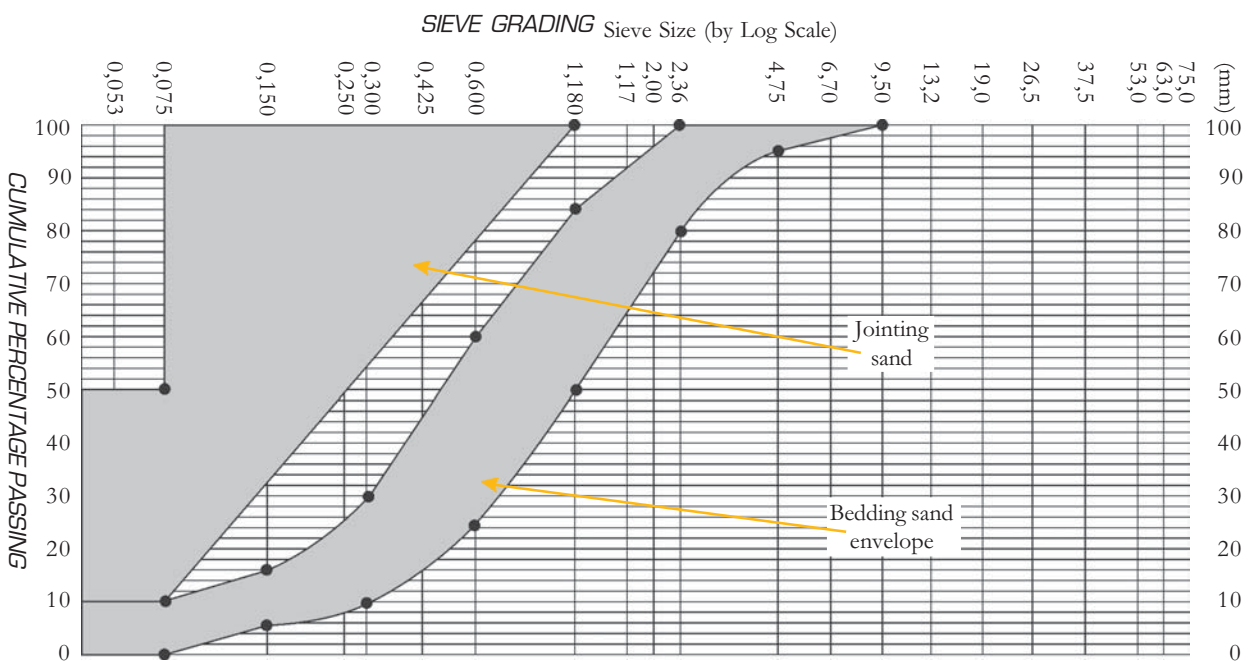

Figure 5: Grading curves for bedding and jointing sands

into a more rigid pavement. This pavement cannot accommodate flexural or thermal movement stresses without distress.

Furthermore, cement tends to discolour the paving and is difficult to remove afterwards.

Where there is a concentration of water such as at a down-pipe or stormwater outlet, it is recommended to mix a little cement with the jointing sand in the immediate vicinity. This will help prevent wash-out. Joints in cbp should be topped up when required, typically three months after construction.

2.6 EDGE RESTRAINTS

Edge restraints are an important element of segmented paving. Edge restraints hold the pavers in position and prevent horizontal creep and the opening of joints under traffic with the subsequent loss of integrity of the pavement. All cbp must have an edge restraint (for details see Book 3). Edge restraints may be cast in situ or precast or could be the existing structures.

2.7 DRAINAGE

Most failures of pavements are due to ingress of water into the pavement layerwork. In order to obviate this problem, attention should be paid to surface drainage and where necessary subsoil drainage.

Adequate longitudinal falls and no undulations are necessary to prevent ponding and infiltration of water into the layer-works particularly in the early life of the pavement. A minimum fall of 2% in any direction is generally required. It is also important to ensure that the paving is laid proud of (ie 5-10 mm higher than) stormwater structures or channels.

Where paving is laid on a slope, water penetrating the paving can accumulate in the bedding sand at the low point. Where a high water table exists, subsoil drainage should be installed.

3 STRUCTURAL DESIGN OF CBP

Under traffic, block pavements tend gradually to accumulate rutting deformations. In this respect the performance of block paving is similar to that of conventional flexible pavements. However, both the amount and rate of accumulation of deformation of the pavement layers in block paving tends to be less than in flexible pavements of similar thickness.

The ability of blocks to spread concentrated loads over a wide area of earthworks layers is well documented. This means that blocks do not merely act as a wearing course, but, rather, form one of the loadbearing courses. In other words the blocks have a significant

structural capacity when properly installed. For axle loads such as those applied by trucks, the block normally provides the principal loadbearing course in the entire pavement. The blocks themselves are hardly affected by high surface stresses. In practice, it is found that, as the design load increases, block pavements can offer increasingly beneficial operational and economic advantages over other pavement types.

Block pavements usually exhibit smaller permanent deformations under traffic than asphalt pavements. However, it should be noted that the converse is often true in the case of deflections. Because of the articulated nature of block paving, large deflections (up to 2 mm or more) have been observed under truck traffic. Such large elastic movements would be unacceptable in other types of pavement and would cause cracking of the surfacing. Because concrete block paving is dissected by a network of joints, large deflections can be tolerated and, except where stabilised bases or subbases are used, are not a design consideration. For this reason the thickness of unbound granular subbase needed in a block pavement is normally less than that required in an asphalt-surfaced pavement.

Under traffic, concrete block pavements tend to stiffen. In some cases this can lead to the pavements achieving a quasi-equilibrium or 'lockup' condition beyond which no further deformation occurs. Often the increase in stiffness in the block layer that accompanies lockup is substantial and it has been reported that it may be possible thereafter to increase the loads applied to the pavement without causing damage. The development of lockup is contingent upon careful control of construction standards and layerworks quality. For example, it has been reported that subbase layers of low bearing values do not permit the development of interlock during the early life of the pavement. Where conditions are favourable for achieving interlock it can be allowed to develop gradually under traffic or may be more rapidly induced by proof-rolling the pavement.

A brief summary of the methods of designing of concrete block paving is given here.

The methods that are available to design block paving roads can be divided into five categories.

- Equivalent thickness concept
- Catalogue design method
- Research-based design methods
- Mechanistic design methods
- Lockpave



3.1 EQUIVALENT THICKNESS CONCEPT

Here it is assumed that the pavement can be designed by established flexible pavement design procedures and that the blocks and bedding sand can substitute an equivalent part of the conventional design. Table 1 gives a summary of the various values of equivalent substitution used in Argentina, Australia, UK and USA. Adopting the item of equivalency described above, it becomes a simple matter to design a block pavement using well established flexible pavement design procedures which incorporate measure of subgrade strength such as Bearing Ratio.

The various design approaches discussed above assume that block paving responds to traffic in a manner which is similar to that exhibited by conventional flexible pavements and that, consequently, there is no impediment to the use of established design procedures. However, this is not strictly correct. Consequently, a criticism of these design methods is that they fail to recognise or exploit those advantages peculiar to block paving such as the development of progressive stiffening and lockup, the ability to tolerate large transient deflections, and the ability to spread the load, thus reducing the stress below the bedding sand.

Country	Concrete block paving is equivalent to...
Argentina	2,5 times their thickness of granular subbase.
Australia	2,1 – 2,9 times their thickness of crushed rock base. 1,1 – 1,5 times dense graded asphaltic concrete.
USA Corps of Engineers	165mm cover. 2 – 2,85 times its thickness of granular base.
United Kingdom	225 mm of soil cement. 160 mm of rolled asphalt.

Table 1: Summary of various factors of equivalent substitution

3.2 CATALOGUE DESIGN METHOD

Here blocks and base thickness are selected on the basis of experience of road construction on subgrades similar to that under consideration. Where the body of experience is extensive, as in Europe, this simple approach can yield satisfactory results. The design procedures are often presented as a design catalogue, which encapsulates local knowledge but which tends to make little distinction between different subgrade conditions or wheel loads. Such methods are, in general, only applicable to roads and not suitable for the design of industrial pavements.

In South Africa we have three design manuals based on catalogue design:

- Draft UTG2. Structural design of segmental block pavements for southern Africa³.
- Guidelines for the provision of engineering services in residential townships⁴.
- TRH 4: Structural design of inter-urban and rural road pavements⁵.

In all cases, the road is classified in terms of traffic volume (as measured by cumulative E80s), traffic type (residential or industrial) and climatic conditions. Once the road has been classified, the catalogue can be used to select the pavement design. (Figure 6 is a typical design taken from UTG2.) The material classes specified for the pavement design are as per TRH 14⁶. However, the catalogue method lacks flexibility (only subgrade strength of CBR = 10 or 15 is accommodated) and will often yield a less than optimal pavement design.

3.3 RESEARCH-BASED DESIGN METHODS

Although many engineers have used tests of prototype interlocking concrete pavements to obtain materials equivalencies or substitution ratios, only one design method appears to be wholly based on accelerated trafficking tests. This is the method developed by Shackel at the University of New South Wales for the Cement and Concrete Association of Australia. This method was first published in 1978. Subsequently, following trafficking tests in South Africa designed, in part, to verify the procedure, the method was slightly revised in 1982. The method is restricted to block pavements subjected to highway loadings and which incorporate unbound granular bases.

It has proved possible to use data gathered during accelerated trafficking tests of full-scale prototype block pavements to develop statistically-based models to relate, for a given subgrade strength, the block and base thickness to such measures of performance as rut depth. These models have been extended to cover the full range of subgrade conditions using mechanistic analyses. Typical design curves are shown in Figure 7. This method has been used successfully in a variety of climates since the late 1970s but has been replaced by mechanistic procedures similar to those described below.

3.4 MECHANISTIC DESIGN METHODS

Several mechanistic procedures for the design of block pavements have been developed. The first was developed in South Africa. Here the block pavements

Road category	Climatic region					
	Design traffic class E80s/lane over structural design period					
	ER	E0 < 0,2 x 10 ⁶	E1 0,2 - 0,8 x 10 ⁶	E2 0,8 - 3 x 10 ⁶	E3 2 - 12 x 10 ⁶	E4 12 - 50 x 10 ⁶
UB	—	—	60 S-A S-B or S-C 20 SND 150 G5 *	60 S-A S-B or S-C 20 SND 150 C4 *	60 S-A S-B or S-C 20 SND 150 C4 *	60-80 S-A 20 SND 125 C4 125 C4 *
UC	80 S-A S-B or S-C 20 SND ***	60 S-A S-B or S-C 20 SND 100-125 G5 *	60 S-A S-B or S-C 20 SND 100-150 G5 *	60 S-A S-B or S-C 20 SND 150 G5 *	60 S-A S-B or S-C 20 SND 125 C4 *	—

*CBR minimum 15% **S-B or S-C may be used in some cases ***CBR minimum 10%

Figure 6: Typical catalogue design of cbp pavement (UTG 2)

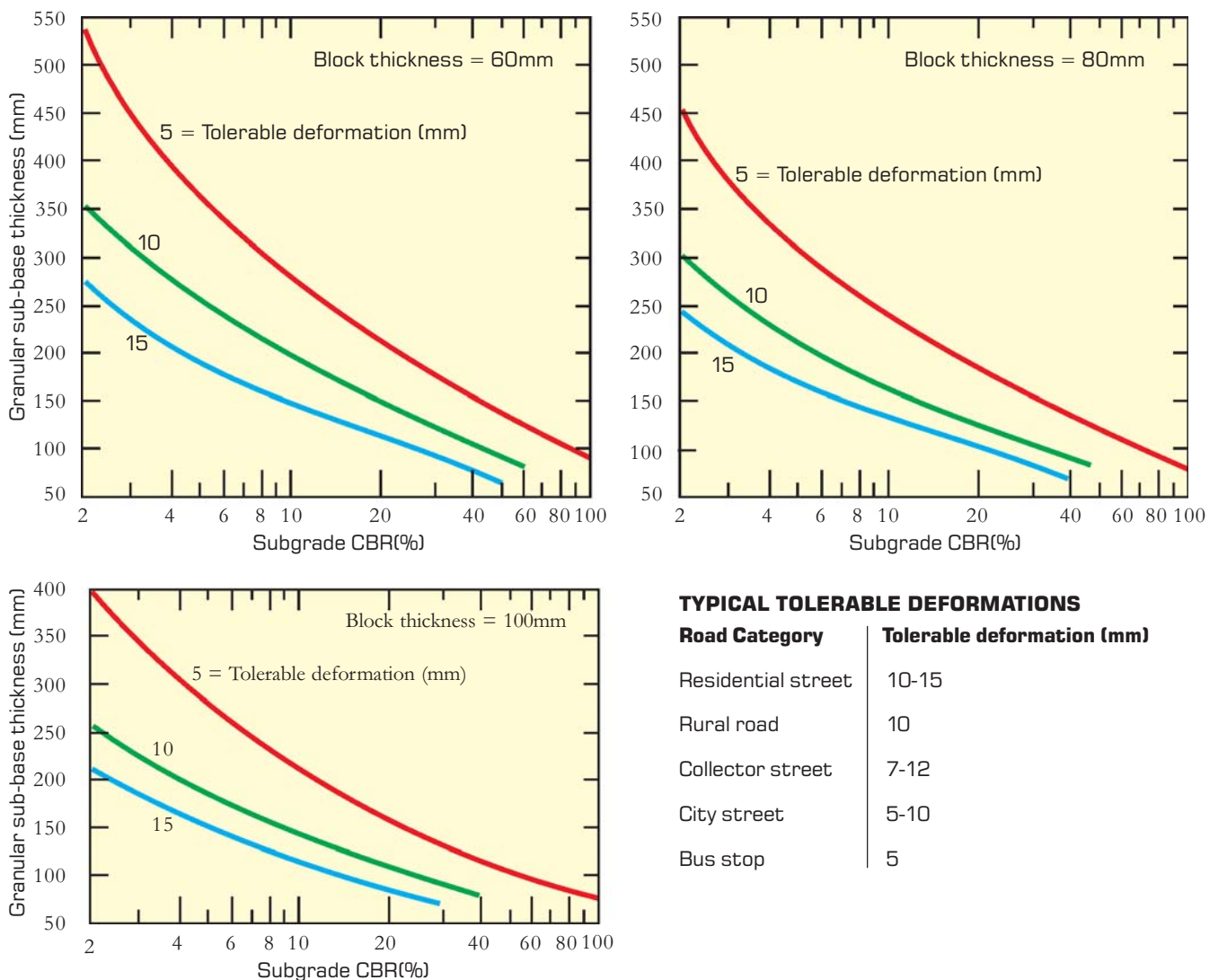

Figure 7: Empirical Design Curves for Road Pavements



were analysed as homogenous isotropic flexible mats overlying a flexible subgrade whose strength was defined in terms of CBR. The second mechanistic analysis was reported in Britain in 1979. The method was based on a three-layer linear elastic analysis of the pavement and assumed that conventional criteria for relating subgrade strain to the expected life of an asphaltic pavement could equally well be applied to a block pavement.

Recently a variety of mechanistic procedures utilising the methodology of conventional flexible pavement design have been developed. Usually these analyses are concerned with either:

- Computing the tensile strains in a bound subbase and thereby defining the fatigue life; or
- Determining the vertical compressive strains in the pavement or granular subbase and using these to predict the rutting that will develop under traffic.

By trial, the thickness of the various pavement layers may be chosen to achieve both an adequate fatigue life and tolerable levels of rut deformation.

Initially, the most effective application of mechanistic methods was in the design of block pavements incorporating bound subbases such as lean concrete or cement-stabilised granular materials. However, in 1985 Shackel published a comprehensive mechanistic design methodology that was suited to both bound and unbound subbases. This procedure was designed to be run, in an interactive mode, on micro-or mini-computers. This design method is now available as a

computer programme called "Lockpave", discussed below. The method is believed to be an advance on earlier mechanistic procedures in so far that it completely avoids the need to use concepts of axle load equivalency but rather analyses and designs each pavement in terms of an appropriate spectrum of axle loads. This is of particular importance in the designing of industrial pavements, which often have to accept a very wide range of wheel loads, vehicle configurations and differing load repetitions for each vehicle type. Examples of design curves for both road pavements and industrial hardstands proposed using this methodology are given in Figures 8 and 9.

3.5 LOCKPAVE

The mechanistic design method has also been developed as a computer programme Lockpave. Mechanistic pavement design involves the formulation and solution of a boundary value problem. This requires the determination of the stresses and strains at critical locations throughout the pavement. These are compared with the values that would, theoretically, be predicted to cause failure of the pavement. As noted above, failure may be the result of either excessive rutting in the case of granular material, or, in the case of bound materials, of extensive cracking leading to a loss of both strength and stiffness. Typically, the critical stresses and strains occur either on or near the vertical load axis at the bottom of all bound (brittle) layers and at the top of the subgrade (see Figure 10). The fatigue life of the bound layers can be related to the repeated tensile strains or stresses

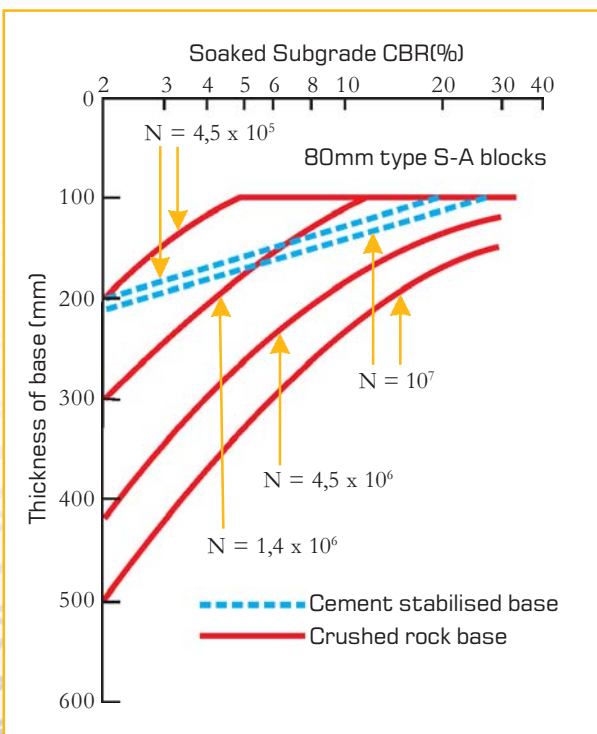

Figure 8: Design Curves for Road Pavement (N= No. of Axles)

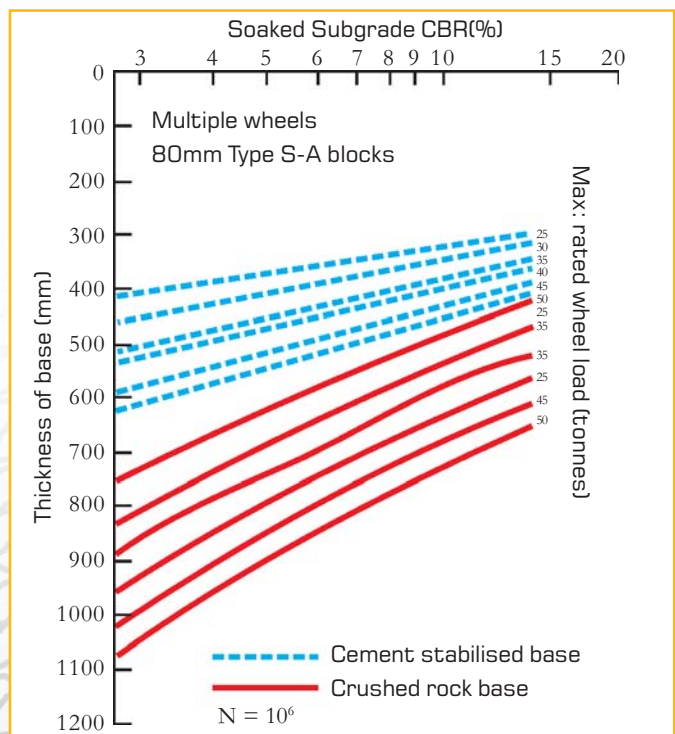

Figure 9: Design Curves for Container-Handling Areas

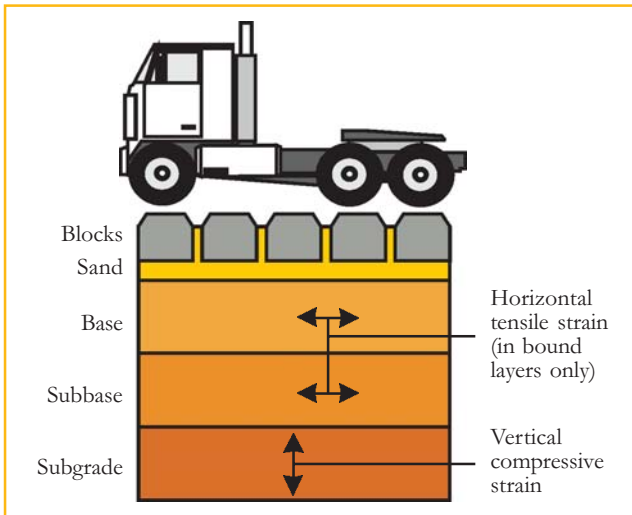

Figure 10: Strains within the pavement

whilst the permanent deformation or rutting of the pavement is normally assumed to be a function of the repeated vertical compressive strains at the top of the subgrade. Provided the critical stresses and strains can be calculated, and Young's modulus of elasticity and Poisson's Ratio of the layerworks are known, it is possible to predict the service life of the pavement. Conversely, for a designated service life, it is possible to calculate what values of stress and strain can be tolerated and, by trial and error, to determine what combination of layer thicknesses are required if these stresses and strains are not to be exceeded.

Thus, mechanistic pavement design involves first the analysis of the stress and strain distributions caused by some designated loading and, secondly, the progressive adjustment of layer thickness until the predicted stresses and strains can be deemed to be insufficient to cause failure within the required service life of the pavement. The adjustment of layer thickness must be done iteratively. This implies that a large number of calculations will be necessary. Because of this and because of the mathematical complexity of analysing layered systems, mechanistic analyses normally require the use of computers.

Further information on the Lockpave programme can be obtained from the CMA.

4 PRELIMINARY DESIGN CONSIDERATIONS

In planning a cbp project consideration should be given to the following.

4.1 PRELIMINARY CONSIDERATIONS

In planning, specifying and designing a pavement, the following factors must be considered:

- The intended usage of the area to be paved
- The type of paving block to be used (interlocking etc)
- The expected service life of the area
- The degree of distress that can be tolerated
- Maintenance

Once these have been specified, design of the pavement may commence and the following factors should receive attention:

- The type of traffic expected
- The imposed loads
- In situ soil conditions and materials
- The availability of materials
- Climatic conditions
- Surface and sub-surface drainage

4.2 CONSTRUCTION

In the construction of the paved area, it is essential that the same criteria of 'good practice' in construction and control be applied to the subgrade, subbase and drainage as would apply in the case of any other type of pavement.

It must further be noted that segmented paving requires adequate edge restraint to the paved area otherwise movement of blocks and loss of performance will occur. The nature of usage will determine the appropriate edge restraint to be used. For example, a pedestrian walkway may only need a small precast concrete kerb or a premix infill, whereas in a high-traffic industrial area heavy duty concrete kerbs or a reinforced concrete ground beam may be necessary.

Should any of the above items not be properly designed and constructed, excessive maintenance may be required during the life of the pavement.

A particularly useful feature of concrete block paving is that it is a 'forgiving' pavement. Thus, where design or construction defects occur locally (such as at manholes, etc) repairs are not usually difficult, time consuming or costly. Segmented paving also permits easy access to underground services since the paving blocks in the area may be removed. The required work can then be undertaken and the same blocks replaced.

5 SPECIAL APPLICATIONS

The method and procedure required to lay concrete block paving for the majority of standard applications is covered in Books 3 and 4. However, there are certain applications where special requirements and



attention to detail are necessary. These special applications are given below.

5.1 CONSTRUCTION OF STEEP SLOPES

There are certain considerations that must be taken into account during the design and construction of concrete block pavers on steep slopes. Refer to CMA technical notes on steep slopes and to Book 3 for factors to be included in the design of steep slopes. These include an anchor beam at the bottom end of the pavement as well as at certain intervals depending on the length and gradient of the slope. Also, special attention must be given to the drainage of the bedding sand layer at the lower end of the pavement against the anchor beam.

5.2 EMBANKMENTS

Concrete block paving is often used for erosion protection of steep embankments, particularly bridge abutments. Although the slopes are generally too steep for traffic and hence the underlying soil need not be well compacted, a reasonable amount of compaction is required to prevent settlement. This is best achieved by constructing and compacting the slope proud of the final line and trimming back. It is also important that the top edge is protected to prevent stormwater undermining the paving.

5.3 INTERSECTIONS

Concrete block paving has been used successfully in South Africa for the construction of intersections primarily to reduce accidents. The reduction of accidents is due to a number of factors, namely:

- Better skid-resistance in the wet and hence shorter stopping distance
- Higher luminance of the pavers
- Difference in surface noise, alerting drivers to a change in situation

Design of the pavement layers must take into account the braking, accelerating and slewing action experienced in intersections.

5.4 AIRPORTS

Concrete block paving has been used for the construction of taxiways and aprons at a number of airports, notably Cairns in Australia, Luton in the UK, and Fort Dallas in the USA. In areas where the pavement is subjected to the immense pressure of the jet thrust, which can result in the loss of jointing sand, it is important that special attention is paid to the sealing of the joints. In the UK, specialised polymers are available for sealing these joints.

5.5 ROOF DECKS

Often, concrete block paving is laid on top of a concrete slab or other impermeable layer. This is not generally a problem. However, attention should be given to drainage, both surface and subsurface. The minimum required fall of 2% is still necessary to remove surface water. However, because of the low falls, this can result in an accumulation of water in the bedding sand. The drainage details discussed under the section "steep slopes" should be used in the lower end of the paving. However, because of the low falls, additional drainage may be required at regular intervals. A typical herringbone drainage layout is suggested. Alternatively, a coarse free-draining bedding sand can be used.

As in all cases, cbp must be contained by edge restraints. Where a parapet wall is used as an edge restraint care must be taken to ensure that the parapet wall has adequate strength to act as a suitable edge restraint. Special attention should also be paid over movement joints in the slab and to how movement is to be accommodated.

6 MAINTENANCE

Maintenance of a well-designed and constructed segmented pavement normally involves the replacement of jointing sand, the treatment of weeds or other growth and the correction of surface levels resulting from localised construction defects.

6.1 JOINTING SAND

In areas exposed to high-speed traffic, or to wind and water erosion, some of the jointing sand between the individual blocks may be lost during the first few months of the life of the pavement. This problem is greatly reduced as the joints between the blocks become clogged with the road detritus and other material. This plugging of the joints is usually well established after about three months of pavement usage.

If there is a loss of jointing sand in the first few months the paving should be resanded. It is advisable for all paving contracts to include a clause on resanding.

In areas subjected to concentrations of water, for example at the outlet of a downpipe from a roof, it is advisable that the jointing sand should incorporate about 10% cement by mass to increase erosion resistance. This should be mixed dry, brushed dry into the joints, vibrated, and then given a light washing down with water to activate the cement. Generally speaking, maintenance of sand in the joints will be

greatly reduced if correctly graded sand is used. The permeability of the joints can be reduced by the addition of 10% lime, or 6-7% bentonite or some clay.

6.2 WEED GROWTH

A common fallacy is the assumption that weeds or other vegetation growing in segmented paving originate in the sub grade or sub-soil areas. In fact ninety per cent of vegetation growth in large paved areas is the result of wind blown seeds, which have germinated in the jointing sand between the blocks. This can easily be proved by removing some of the vegetation and observing where the stem ends and the roots begin. In most cases this occurs just below the surface of the blocks and hence in the jointing sand.

Where vegetation is likely to cause a maintenance problem, eg Kikuyu grass growing from beneath the blocks, a suitable herbicide may be mixed with the jointing sand or sprayed over the completed paving. Care should however be exercised since the injudicious use of poisonous substances may result in extensive damage to cultivated areas. Herbicides, having no residual effect are available to control both annual and perennial weeds. They will not contaminate water supplies or damage other vegetation when distributed by surface run-off during rainstorms. Expert advice on the choice of herbicides should be sought- eg. from the Department of Agriculture and from reputable manufacturers.

The use of plastic sheeting under paving blocks as an inhibitor of vegetation growth due to wind-blown seeds in the joints is not recommended.

6.3 ABRASION

With pavers subjected to intense trafficking, there will be a degree of abrasion with time. The extent of the abrasion will depend on the traffic, the type of aggregates used, the cement content, the ratio of coarse to fine aggregates, control in manufacture and initial curing.

Provided the pavers are of adequate strength, the abrasion does not affect the structural integrity of the paving. Furthermore, the degree of abrasion diminishes with time.

6.3 SETTLEMENT/SUBSIDENCE

From time to time, there is settlement of the pavement surface. This is due to an inadequate subbase or subgrade, the presence of subsoil water, overloading the pavement or a bedding sand layer which is too thick. The benefit of cbp is that the areas can be lifted, the problem addressed, the level reinstated and the pavers re-laid.

6.4 REINSTATEMENT OF TRENCHES

Periodically, pavements have to be dug up to access underground services. The advantage of cbp is that the blocks can be lifted, the trench dug, services installed or repaired, the trench refilled and paving reinstated. Details of this operation are covered in Book 4.

6.5 EFFLORESCENCE

Efflorescence results when free lime in the cement is dissolved and carried by water to the surface of the paver and is deposited there once the water evaporates. Efflorescence results in a whitish or light colouring on the surface of the pavers. Efflorescence (if it does occur) generally occurs in the early life of pavers and particularly when water is present and it is cold. Efflorescence is mostly a temporary effect and, given time, usually disappears of its own accord. It is purely superficial and does not affect the durability or strength of the concrete paving units.

If immediate removal is required, the pavers can be given an acid wash - see technical note.

6.7 OIL STAINS

Concrete block paving is frequently used for garage forecourts, taxi and bus termini and parking areas. As a result the surface is often spoilt by oil stains. The fact that cbp is not affected by this is very positive. However, to remove these stains poses a problem. There are proprietary products which have been designed specifically for this purpose. If these are not available then it is recommended that the paving be scrubbed with a strong detergent and washed down with water.

7 CONCLUSION

Good pavement management requires that the condition of pavements be consistently maintained above a minimum level. Visual inspections are usually satisfactory in determining this level for segmented pavements.

The degree and extent of maintenance will depend on the standards and criteria required of the pavement.

Provided that proper design and construction techniques are observed, and the possible problem areas discussed above are recognised and treated, a segmented concrete block pavement is indeed 'maintenance free'.



8 CASE STUDIES

The following pages contain a number of case studies of the design of concrete block pavements including the traffic estimates. These studies are given as a guide only and are not to be used for the design of other projects. The case studies do not include lightly-trafficked pavements as these are generally not designed by an engineer.

8.1 RICHARDS BAY HARBOUR

Port pavements are typically constructed over weak subgrades on reclaimed ground, which may be subject to long term settlement. However, the pavement must be capable of withstanding the heaviest of wheel loads as well as high concentrated point loads, without significant permanent deformation or other distress.



In addition, the pavement should remain unaffected by spillage of hydraulic oil which is normally associated with heavy materials handling equipment, or by environmental effects such as high surface temperatures.

In view of its proven track record in coping with a combination of these circumstances, together with both operational and life-cost advantages over alternative pavements, it was decided to use concrete block paving in the iron and timber product handling terminal at Richards Bay.

The project managers were well aware, in making this choice, that concrete block paving (cbp) remains serviceable, despite the occurrence of settlement. Should the need arise, periodic correction of

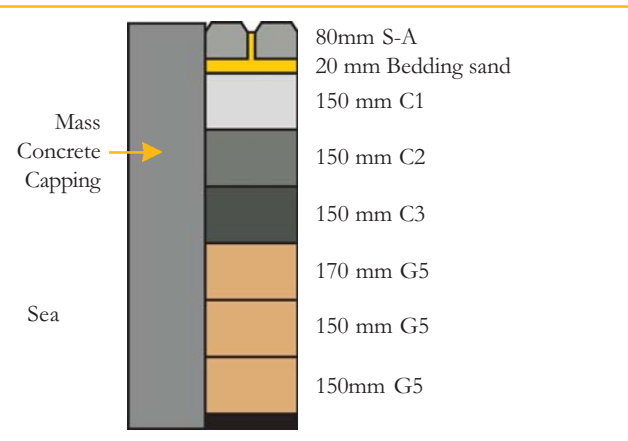

Figure 11: Typical section through pavement showing sub base design at quay side.

settlement is easily achieved by lifting the block surface and reprofiling the pavement substrate.

Moreover, maintenance costs for cbp have in general been found to be significantly lower than for other forms of flexible and rigid pavement.

8.2 PINETOWN TRAFFIC INTERSECTION

INTRODUCTION

One of the perennial problems faced by town councils, municipalities and other local authorities countrywide is the need to regularly refurbish and maintain existing road surfaces in busy traffic intersections. A workable solution is to replace the existing conventional road surfacing with concrete block paving.



BACKGROUND

Due to the on-going deterioration of the existing road surface as well as increasing traffic flows, the Borough of Pinetown found it had to upgrade the Anderson Road/Old Main Road traffic intersection during the latter part of 1988. The scope of the project included road widening in Anderson Road and Old Main Road, reconstruction of Anderson Road South and resurfacing of the entire intersection area.

Anderson Road forms the first intersection with Old

Main Road on the eastern side of the railway line, bordering the central area of Pinetown, and serves the main Hill Street bus terminal to the south and residential and commercial areas to the north.

PROPOSAL

In September 1988 a proposal was put forward by Grinaker Precast (Natal) (Pty) Ltd to pave the intersection using interlocking concrete paving blocks.

As considerable success had already been achieved in several similar projects carried out overseas, one of the primary objectives was to provide a local research project to demonstrate the benefits associated with, and arising from the use of concrete block paving (cbp) in a heavily used urban traffic intersection.

The severe conditions, due to a daily traffic flow of over 30 000 vehicles, (including 2000 buses), made this an ideal test site.

Having accepted the proposal, the Council duly instructed the consulting engineers, De Leuw Cather Inc, to incorporate it in their overall planning.

STRUCTURAL DESIGN ASPECTS

Based on profiles taken from test pits dug in the intersection area, it was found that the existing premix layer was up to 230 mm thick in places, and was supported on a primary subbase of crusher-run material varying in thickness from 100 mm to 320 mm. The existing overall pavement depth averaged 1100 mm.

Had the cbp proposal not been made and accepted, the existing road surface would have been overlaid with a 40 mm premix layer:

A traffic survey undertaken by the consulting engineers, together with estimates of E80 axle loads over a 20-year design period, led to the decision to opt for a heavy duty class E4 pavement design.

In areas of the intersection which were to be widened, and where new road construction was required, the design was based on the catalogue of structural design for segmental block pavements for southern Africa³. A

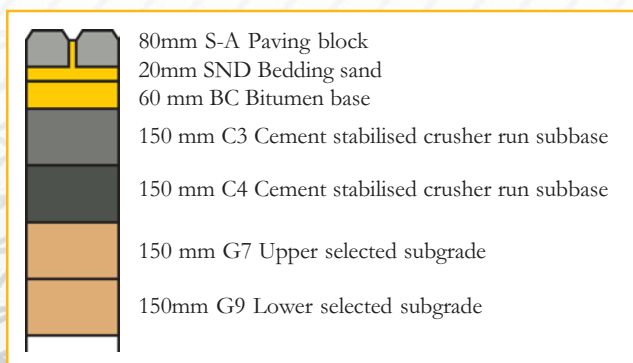

Figure 12: Detail showing typical section through new road construction.

60 mm bitumen base was included for purposes of levelling existing subbase layers and for trafficking during staging of the construction work, prior to laying the blocks.

Where blocks were to be laid on top of the existing road surface, and in order to accommodate original kerb lines, the existing asphalt was milled by up to 100 mm to achieve desired levels. Roughly 40m³ of asphalt was removed from the intersection. Premix was used as a levelling course to fill low points and achieve a constant crossfall, as well as being used at the approaches to the intersection to ensure a smooth transition between the existing asphalt surface and the new block paving.

SPECIFICATION OF CONCRETE BLOCK PAVERS

Concrete block paving is a system of individual, shaped blocks arranged to form a continuous hard-wearing surface. The specification called for 80 mm thick blocks; shape S-A (providing positive geometric interlock along all vertical faces); class 35 (having a minimum compressive strength of 30 MPa) – manufactured in accordance with the standard specification for concrete paving blocks (SANS 1058)⁵. For economic reasons the colour specified was natural grey.

A herringbone laying pattern was chosen to ensure optimal performance of the pavement under very heavy traffic, with the added advantage of being able to follow directional changes in the varying road alignment without needing to break bond. The interlocking block's shape combined with this laying pattern facilitates even load distribution, and resists rotation and lateral movement of individual blocks in relation to one another. Due to the pavement becoming 'locked up' horizontal creep of the overall paved surface is also reduced.

8.3 BELLVILLE GOODS YARD

Bellville Goods Yard is the central handling depot for most of Transnet cargo traffic between Cape Town and





the hinterland. Typical daily traffic includes \pm 220 thirty-ton vehicles as well as 54 fork-lifts of 10,5 and 14 tons. Besides the normal movements there is static loading under parked vehicles. The design chosen to accommodate this traffic includes 150 mm cement-stabilised crusher-run base with 80 mm grey interlocking (type S-A) concrete block pavers laid in herringbone pattern (see Figure 13 for details)

36 500m² of paving was designed and installed during 1987-1988. To date, there has been no maintenance and the paving has performed very well, as the photograph shows.

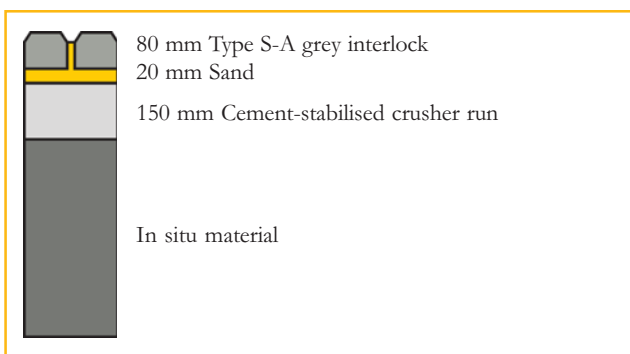

Figure 13: Pavement design - Bellville Goods Yard.

8.4 TRIDENT STEEL MAXMEAD PINETOWN

The Trident Steel site is situated in the industrial township of Maxmead in Pinetown. The earthworks on the 10 000 m² area, consisted of an engineered cut to fill of clay having a CBR of between 1% and 4%. The in situ material was stabilised with lime to provide a working platform and three imported layers, as detailed, were constructed. The main structural steel building is founded on augured friction piles to a depth of between 8m and 12m.



A box culvert traversed the site 10 m below the final surface to collect the natural stormwater run-off. From

geotechnical testing it was established that considerable settlement in the order of 200 mm was likely. With the high load and low subgrade conditions, no cost-effective pavement could be constructed to distribute the load further and hence reduce settlements.

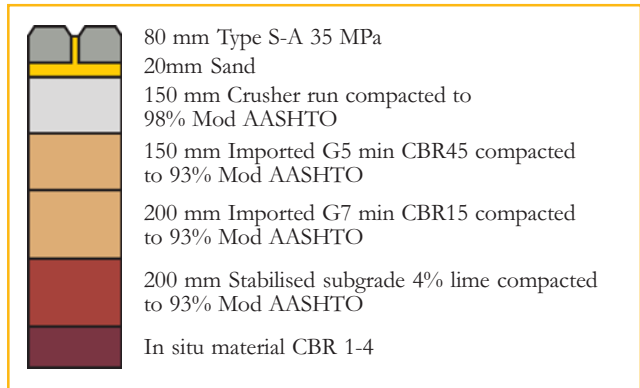

Figure 14: Pavement design Trident steel.

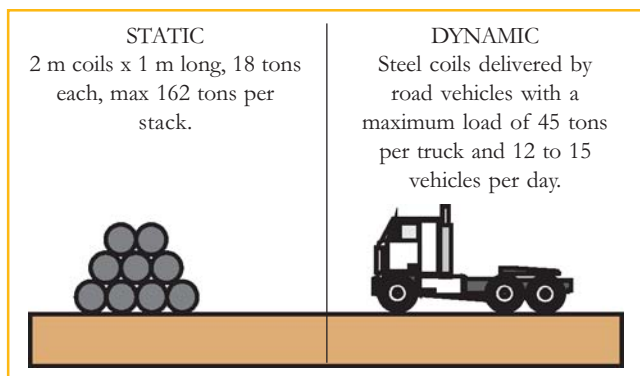

Figure 15: Static and dynamic loading on factory floor

8.5 JOHANNESBURG NORTHERN WASTEWATER TREATMENT WORKS

Concrete block paving was used to pave 90 000m² at the Johannesburg Northern Wastewater Treatment Works. Roadways accounted for 25000m², terraces 40 000m² and the embankments 25 000m². The pavement design for the various applications is given below.



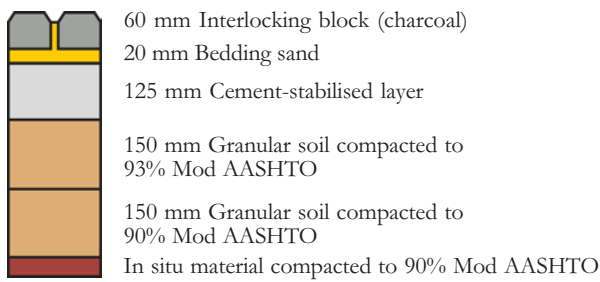

Figure 16a: Pavement design — Roadways

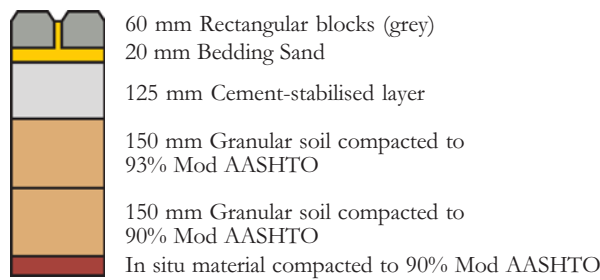

Figure 16b: Pavement design — Terraces

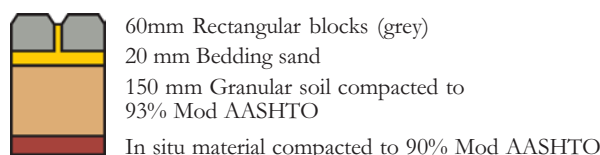

Figure 16c: Pavement design — Embankments

8.5 PIETERSBURG TRAFFIC INTERSECTION

BACKGROUND

The Pietersburg intersection of Hoof Street and Iran Avenue carries a high volume of heavy vehicle traffic.

Traffic counts of the order of 21 000 vehicles per 12-hour period have been recorded, of which over 20% are heavy vehicles. With the expected increase in traffic to Louis Trichardt, Messina and Zimbabwe it was critical that this intersection, as the principal thoroughfare, should be able to withstand this increase, particularly with regard to heavy vehicles.

TECHNICAL ASPECTS

Consideration of such factors as the importance of the intersection, slow-moving heavy vehicle traffic and slewing movements, as well as the expected growth in traffic volumes, led the consulting engineers to use the layer design based on a B category road and E3 traffic class. (See figure 17a) The total paved area of 4950 m² was hand packed in a period of less than three weeks.

One of the most critical aspects of the construction process was to ensure complete accuracy of construction in the final earthworks layer. The thickness of the bedding sand layer should not be varied to make up for inaccuracies in the surface of the layer below as such practices can lead to the pavement sagging. A mixture of sand and cement was used to correct any minor inaccuracies.

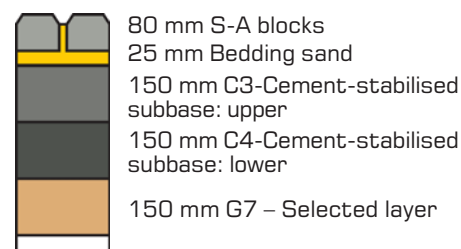

Figure 17a: Pietersburg intersection road-profile.

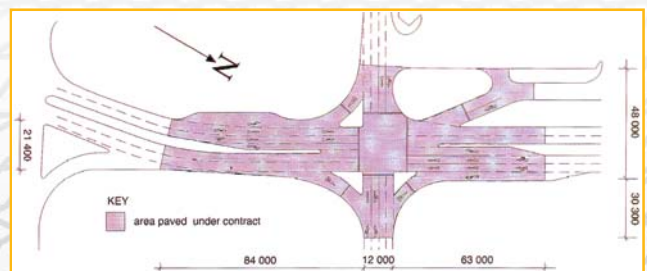

Figure 17b: Plan-view of intersection showing junction with adjacent asphalt roads.



8.6 ANALYSIS OF A CONCRETE SEGMENTAL ROAD PAVEMENT

CMA Lockpave Version 10.8

Job name: Design Aspects Manual

Client: CMA

Area of Job: 1000 sq m

Analyst: John Cairns

Date: 4/7/1999

Time: 16:14:10

PAVEMENT ANALYSIS ASSUMPTIONS

Layer No	Thickness (mm)	E (MPa)	Mu	Materials Type
1	60	3200	.3	Pavers
2	25	200	.35	Bedding sand
3	100	2300	.35	Cement-stabilised base
3	?	250		Gravel
5	Semi-Inf E-varies		.4	Subgrade

Drainage Factor for unbound materials: .85

TRAFFIC DATA

Road class: Arterial

Average Traffic Daily: 7 500

Growth rate: 3% PA

Analysis period: 20 YEARS

Directional split: 50%

Proportion of trucks: 10%

Total number of ESALs in whole life: 2 263 371

PAVEMENT COMPRISES

Surface: 80mm Type S-A Pavers laid in herringbone bond

Sand: 25mm of bedding sand

Base: Cement-stabilised granular compacted to 96% modified MDD

Subbase: Gravel compacted to 95% modified MDD

Subgrade: See Table below for Soaked CBR values

Drainage: Stated to be average – Subsoil drainage should be considered

CBR %	Thickness of subbase mm
1	465
3	225
5	130

9 REFERENCES

- 1 SANS 1058- 1985, Standard specification for concrete paving blocks, Pretoria: South African Bureau of Standards, 1985.
- 2 Shackel, B.A pilot study of the performance of block paving under traffic using a heavy vehicle simulator, CSSA symposium on precast concrete block paving, Johannesburg, Nov. 1979.
- 3 Committee of Urban Transport Authorities, Structural design of segmental block pavements for southern Africa, Pretoria: NITRR, SCIR, 1987, (draft UTG 2)
- 4 Guidelines for the provision of engineering services and amenities in residential township development, rev. ed. Pretoria: Boutek, CSIR, 1994
- 5 Structural design of interurban and rural road pavements, Pretoria: NITRR, CSIR, 1985. (Technical Recommendation for Highways TRH 4)
- 6 Guidelines for road construction materials, Pretoria: NITRR, CSIR, 1985. (Technical Recommendations for Highways TRH 14).

FURTHER READING

- Shackel, B. Design and construction of interlocking concrete block pavements, London: Elsevier, 1990.
- SANS 1200MJ 1984, Standard specifications for civil engineering construction. Part MJ, Segmented paving, Pretoria: South African Bureau of Standards, 1984.